

DAVID
BURR



The Jug & Bottle, High Street, Clare, Sudbury, Suffolk CO10 8NY

An opportunity to acquire a prominent Freehold retail premises in the heart of Clare. The Jug and Bottle is a renowned historic business forming part of a Grade II listed building just a short walk to the church and further amenities.

Guide £47,500

The Jug & Bottle, High Street, Clare, Sudbury, Suffolk CO10 8NY

An opportunity to acquire a prominent retail premises located on the High Street in the heart of Clare. The Jug & Bottle is a renowned and historic business situated in the heart of Clare forming part of a Grade II listed building overlooking the High Street, just a short walk to the church and further amenities.

The property comprises one room with large windows to the front with built in shelving and a counter with water connected and side access. The current planning permission is for food and beverages, however we are confident a change of use could be sought from the Local Authority. The property is alarmed and offered Freehold.

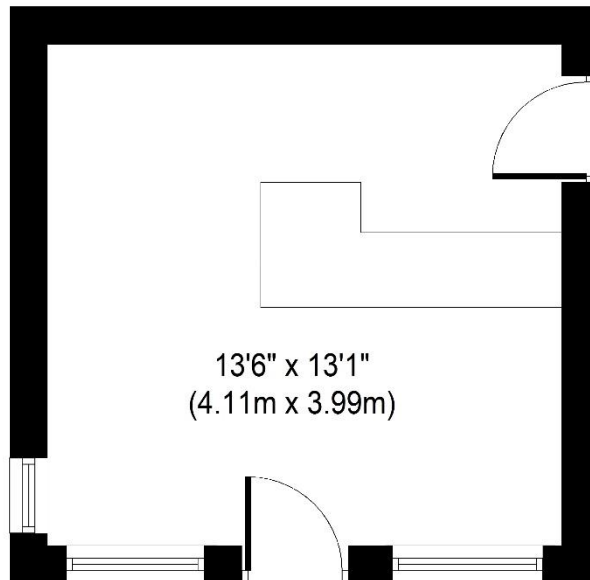

Approximate Floor Area
176 Sq. ft.
(16.4 Sq. m.)

Whilst every attempt has been made to ensure the accuracy of the floor plan contained here, measurements of doors, windows, rooms and any other items are approximate and no responsibility is taken for any error, omission, or mis-statement. The measurements should not be relied upon for valuation, transaction and/or funding purposes. This plan is for illustrative purposes only and should be used as such by any prospective purchaser or tenant. The services, systems and appliances shown have not been tested and no guarantee as to their operability or efficiency can be given.

Copyright V360 Ltd 2023 | www.houseviz.com

Viewing strictly by appointment with David Burr.

Castle Hedingham (01787) 463404
Clare (01787) 277811
Leavenheath (01206) 263007
Long Melford (01787) 883144
Newmarket (01638) 669035
Woolpit (01359) 245245
Bury St Edmunds (01284) 725525
Linton & Villages (01440) 784346
London (020) 78390888
DAVIDBURR.CO.UK

Additional information

Tenure: Freehold.

Services: Water and electricity. Agent's Note: There are no mains drains connected to the property.

Local Authority: West Suffolk Council – 01284 763233.

NOTICE. Whilst every effort has been made to ensure the accuracy of these sales details, they are for guidance purposes only and prospective purchasers or lessees are advised to seek their own professional advice as well as to satisfy themselves by inspection or otherwise as to their correctness. No representation or warranty whatever is made in relation to this property by David Burr or its employees nor do such sales details form part of any offer or contract.